

Allozyme and craniometric variability in the Roe Deer (*Capreolus capreolus* L.) from Central Italy

By RITA LORENZINI, L. MATTIOLI, M. RUSTIONI, and MARIANNA PATALANO

Istituto Zooprofilattico Sperimentale dell'Abruzzo e del Molise "G. Caporale", Teramo, Italy;
D.R.E.A.M. Settore Fauna, Poppi, Arezzo, Italy; Dipartimento di Scienze della Terra, Università di
Firenze, Italy.

Receipt of Ms. 16. 05. 1995
Acceptance of Ms. 29. 09. 1995

Abstract

Roe deer from the provinces of Siena and Arezzo, Central Italy, were investigated for genetic and morphometric differentiation. A total of 162 individuals from seven sampling sites (4 in Siena, 3 in Arezzo) were analysed at 40 presumptive gene loci by means of vertical polyacrylamide gel electrophoresis. Seven loci were polymorphic for at least two alleles. The mean proportion of polymorphic loci (P) was 16.2% in Siena, and 15.8% in Arezzo. Mean expected heterozygosity (H_e) was 5.3% and 4.0% in Siena and Arezzo, respectively. Both the values of relative ($F_{ST} = 8\%$) and absolute (mean Nei's 1972 $D = 0.007$, mean modified Rogers $D = 0.084$) genetic distance suggest a significant differentiation between the subpopulations of Siena and Arezzo, possibly due to the different demographic origin of roe deer from the two provinces. Morphometric variation in 28 cranial and mandibular traits, measured in 48 individuals, was subjected to principal component and discriminant function analyses. Both methods allowed a quite clear separation of specimens from the two provinces, revealing significantly greater skull dimensions in the roe deer from Arezzo. Although genetic factors might be involved, a higher density of deer within the wooded areas of Siena was hypothesized as the main environmental cause of morphometric differentiation.

Introduction

The roe deer, *Capreolus capreolus* (Linnaeus, 1758) is recognized as one of the most ecologically adaptable species of deer (NEUHAUS and SCHAICH 1985; LEHMANN and SÄGESSER 1986; KURT 1991). Its great biological plasticity enabled this species to colonize different habitats successfully, e. g. wooded areas or open cultivated landscapes. Field and forest dwelling roe deer have been identified as different ecotypes, showing remarkable phenotypic variability and differences in breeding biology and social organization (PIELOWSKI 1977; FRUZIŃSKI et al. 1982; FRUZIŃSKI and ŁABUDZKI 1982; MAJEWSKA et al. 1982; PIELOWSKI and BRESIŃSKI 1982; KURT 1991).

The intraspecific morpho-ecological variation observed between different forms could be generated by comparatively high genetic differentiation, justifying the existence of distinct subspecies or geographical ecotypes. On the other hand, the reaction norm of the genotype of roe deer could be responsible for a wide range of phenotypic variation induced by gene-environment interactions. Extensive studies on the morphometry, ecology, and biochemical-genetic variability of the European roe deer have been conducted to date. These investigations attributed the wide intraspecific variation of this deer to the dy-

dynamic rearrangement of genetic diversity within populations and to different habitat conditions (MARKOWSKI and MARKOWSKA 1988; ZEJDA and KOUBEK 1988; ZIMA 1989; ZIMA et al. 1989; FANDOS and REIG 1993; MARKOWSKI 1993), to human activities such as hunting and/or reintroductions (HARTEL et al. 1991; LORENZINI et al. 1993), to the breeding behaviour (APOLLONIO and HARTL 1993; KURT et al. 1993), and to population histories (LORENZINI et al. 1993). These results seem to indicate that there are no emerging subspecies of *Capreolus capreolus*, rather they suggest a high phenotypic plasticity of this species. This view is reinforced by analyses of non-metric variation. FANDOS and ORUETA (1991) detected a high variability in epigenetic skull traits of roe deer from the western Cordillera Cantabrica and suggested an adaptive value for most of those characters. Similar investigations revealed a high level of genetic variability also in populations from Poland (MARKOWSKI and MARKOWSKA 1988). However, no significant differences between animals living in field and forest habitats exist either in cranial non-metric traits, or in fluctuating asymmetry (MARKOWSKI 1993).

We studied forest dwelling roe deer for biochemical-genetic and morphological variation. The aim was to investigate the level of differentiation between some populations from central Italy in relation to their different demographic backgrounds and environmental conditions.

Material and methods

A total of 162 roe deer from the provinces of Siena and Arezzo, Tuscany, Italy, were investigated. Specimens were collected from four sampling sites (called subpopulations here) in Siena and three in Arezzo (Fig. 1).

The Arezzo population inhabits areas situated at 210–870 m above sea level, with a mean wood cover of 57.4%. According to censuses carried out in 1989 and 1990, the mean density was 10.3 deer/100 ha of the total area (LOVARI et al. 1991). This population, derived from an original stock which lived in the Foreste Casentinesi, North-Eastern Apennines, has been supposed to be autochthonous (LORENZINI et al. 1993). Apart from a post war release of four individuals from the Alps, no other introduction of roe deer occurred from other stocks (CRUDELE 1988; MATTIOLI 1994). The Siena population lives at lower altitudes (150–500 m above sea level) with a mean wood cover of 26.3%. In 1989/90 the mean density was 9.6 deer/100 ha of the total area (LOVARI et al. 1991). It was formed by animals supposed to come from the Latium Maremma, and with allochthonous individuals released into the province probably from Great Britain and the former Czechoslovakia at the beginning of the century (MAZZONI DELLA STELLA 1991). The distribution areas of the two populations met along a narrow strip only very recently, due to the spreading of roe deer from their centers of origin (Fig. 1).

Heart and liver samples were collected from regular hunting during the seasons from 1989 to 1991, and stored at -20°C until electrophoresis. Preparation of tissue extracts, electrophoretic conditions and staining procedures followed standard laboratory protocols (LORENZINI et al. 1993) adapted from SHAW and PRASAD (1970), HARRIS and HOPKINSON (1976), and MURPHY et al. (1990). Thirty enzyme and protein systems encoded by 40 presumptive gene loci were analysed for polymorphisms. Loci were the following (E. C. numbers are given in parentheses): Sod-1, -2 (1.15.1.1), Aat-2 (2.6.1.1.), Est-1, -2 (3.1.1.1), Gpd (1.1.1.49), Pep-A, -B (3.4.11), Fum (4.2.1.2), Adh-1, -2 (1.1.1.1), Ldh-1, -2 (1.1.1.27), Mod-2 (1.1.1.40), Idh-2 (1.1.1.42), Pgm (2.7.5.1), Mpi (5.3.1.8), Ck (2.7.3.2), β -Gus (3.2.1.31), Ada (3.5.4.4), Pgd (1.1.1.44), Pox-2 (1.1.1.7), Acp-1 (3.1.3.2), Mor-1, -2 (1.1.1.37), Dia-1 (1.6.2.2), Gpi (5.3.1.9), Gdh (1.1.1.47), Xdh (1.2.3.2), Hk-2 (2.7.1.1), Ak-1, -2 (2.7.4.3), Hbdh (1.1.1.30), Alb, Trf, Hb-1, -2, Heart-Gp-1, -2, -3. Genotype frequencies were obtained directly by scoring the gels. Observed single locus heterozygosity (h_o) was tested against the expected heterozygosity (h_e) based on the Hardy-Weinberg law by chi-square goodness-of-fit analysis (SOKAL and ROHLF 1981). For each subpopulation estimates of observed (h_o) and expected (h_e) average heterozygosity, and the proportion of polymorphic loci (P) were computed. F-statistics (WRIGHT 1978; NEI 1977) were calculated for each locus to quantify the relative genetic differentiation among subpopulations (F_{ST}), and the level of inbreeding in each subpopulation (F_{IS}) or in the population as a whole (F_{IT}). The inbreeding coefficient F (WRIGHT 1951) was also computed. Statistical significance of the F_{ST} and F_{IS} fixation indices was tested with a chi-square test follow-

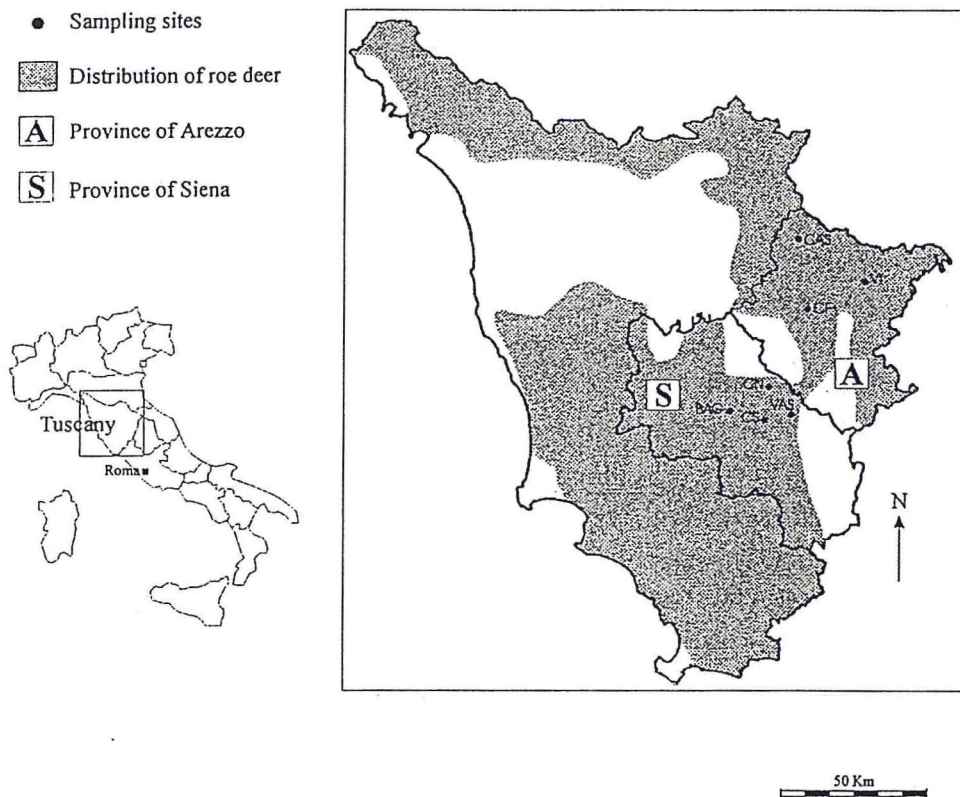

Fig. 1. Sampling sites of *Capreolus capreolus* in the provinces of Siena (CN = Crete Nord, CS = Crete Sud, BAG = Bagnai, VAS = Valdasso), and Arezzo (CAS = Casentino, CF = Castiglion Fibocchi, VT = Val Tiberina).

ing the methods of WORKMAN and NISWANDER (1970), and NEI (1977). The significance of F_{IT} was tested with a t-test according to GOULSON (1993). UPGMA (SNEATH and SOKAL 1973) and Fitch-Margoliash (FELSENSTEIN 1979) dendrograms were constructed using NEI's (1972) standard genetic distance. A distance Wagner tree (FARRIS 1972) was computed with modified Rogers D (WRIGHT 1978) and rooted at midpoint. Electrophoretic data were evaluated statistically by the program BIOSYS-1 of SWOFFORD and SELANDER (release 1.7, 1989).

A total of 28 cranial and mandibular measurements were made on skulls of 48 males. Since the skulls belonged to pre-existing collections, we were not able to trace the respective sampling sites of specimens to infer some microgeographic differentiations within provinces. Therefore, the samples under study could only be ascribed as belonging to the two main populations of Siena and Arezzo. Roe deer is supposed to be completely developed in skull and mandible growth at about three years of age, although full agreement is not achieved by all authors (GOTTSCHLICH 1963; HANUŠ and FIŠER 1979). Because of hunting management, the adult male population was shot randomly. Thus, two-year-old animals were sampled as well. This was not a source of bias since the difference in the proportion of the two-year-old specimens in both Siena and Arezzo samples was not significant (chi-square = 0.43, d. f. = 2, $p > 0.75$).

The age was estimated by tooth wear (AITKEN 1975). Measurements, recorded with a dial caliper to the nearest 0.01 mm, were as follows: condylobasal length (CBL), basal length (BASL), short lateral facial length (LFL), prosthion-P2 length (PML), greatest prosthion length (PRL), length of the nasals (NASL), total skull length (TSL), greatest width across the nasals (NASW), greatest frontal width (FRW), least width between the orbits (ORW), neurocranium width (NEUW), width of the occipital

condyles (COW), zygomatic width (ZYW), width of the right pedicle (RPW), width of the left pedicle (LPW), length from prosthion to M3 (M3L), minimum width at the crest of the maxilla (CMW), length of the premolar row (PMAL), length of molar row (MTL), length of the upper third molar (M3LE), length of the mandible from infradentale to condyle (COLM), height of the mandible (HEM), length of the diastema (DL), length of the cheektooth row measured along the alveoli on the buccal side (TRL), length from the angle of the mandible (GOLM), length of the premolar row of the mandible (PRML), length of the molar row of the mandible (MML), length of the third molar of the mandible (M3MA). Variables were named and measured according to VON DEN DRIESCH (1976).

Mean, standard deviation, and coefficient of variation were computed for all the absolute values of dimensions. Interpopulation difference in mean values for each measurement was evaluated using the Student's t-test. Ratios of mean values of the two samples were represented as logarithms in a ratio diagram. Morphometric relationships in multivariate space were assessed using two methods: principal component analysis, PCA, and discriminant function analysis, DFA, (ANDERSON 1971; MORRISON 1975). PCA allows the projection of multidimensional clouds of points into a space of two or three dimensions which provides a graphical representation of the reciprocal location in space of different groups. Moreover, examination of variable loadings on each axis gives an indication of the relative weight of any single measurement to variation along that axis. The principal components were extracted from a correlation matrix and subjected to VARIMAX rotation to obtain simplified orthogonal axes. DFA was performed on the components extracted by PCA, so that the number of original measurements was limited to a few common factors. The choice of a subset of variables which best summarizes the total variation is sometimes recommended, since characters with little discriminating power can have destabilizing effects on correct classifications (WILLIAMS et al. 1990). Occasionally skulls were damaged and hence not all measures could be recorded for each sample. Records with missing values were deleted. To satisfy completely the assumptions of multivariate normal distribution of the data, a transformation to natural logarithms of the absolute values of all measurements was performed prior to the computations. However, the use of log. instead of raw data did not yield different results. In order to remove partly the effect of size variation between groups, multivariate analyses were also conducted on the relative values of measurements, expressed as percentage of the total skull length. All the statistical analysis were done using the SPSS/PC+ package release 4.0 by NIE et al. (1975).

Results

Genetic variation

Biochemical-genetic variants were observed at seven out of the 40 loci clearly resolved in all subpopulations (Tab. 1). No fixed allelic differences were found among samples, although one of the two low frequency alleles at the Hk-2 locus (Hk-2 "a") was present in only the subpopulations of the province of Siena, whilst the other (Hk-2 "b") was found in those of the province of Arezzo ("private alleles", cf. SLATKIN 1985). Samples revealed marked differences in allele frequencies at five loci (Mpi, Mod-2, Pgm, Ak-1, Hk-2), this being rather due to heterogeneity between the two provinces than to differences among subpopulations within the provinces. Differences among subpopulations within the provinces in terms of WRIGHT's (1978) fixation index F_{ST} were not significant ($p > 0.1$, not shown). The differentiation among all subpopulations gave F_{ST} values (Tab. 2) ranging from 0.038 at Hk-2 to 0.195 at Mod-2. Single locus contingency chi-square tests yielded highly significant F_{ST} values for Mod-2, Pgm and Ak-1 ($p < 0.001$). Mpi and Hk-2 showed chi-square values significant at $p < 0.05$, whereas no significant differences were found for the Acp-1 and the Pep-B allele frequencies. Single locus contingency chi-square tests for departures from Hardy-Weinberg equilibrium revealed a significant heterozygote deficiency at Pgm (chi-square = 10.0, d.f. = 1, $p < 0.01$) in one of the subpopulations of Siena (VAS). Mpi showed a significant heterozygote deficiency as well (chi-square = 13.2, d.f. = 1, $p < 0.001$) in one of the subpopulations of Arezzo (CF). In these subpopulations a consistent excess of homozygotes was demonstrated also by the positive values of WRIGHT's (1951) inbreeding coefficient ($F = 1.000$ and 0.774, respectively, for Pgm and

Table 1. Allele frequencies at seven polymorphic loci in seven roe deer subpopulations from the provinces of Siena and Arezzo, central Italy. CN = Crete Nord, CS = Crete Sud, BAG = Bagnai, VAS = Valdasso, CAS = Casentino, CF = Castiglion Fibocchi, VT = Val Tiberina. Sample sizes in parentheses.

Locus	Allele	Siena				Arezzo		
		CN (32)	CS (29)	BAG (22)	VAS (10)	CAS (35)	CF (22)	VT (12)
Pep-B	a	0.688	0.690	0.750	0.700	0.600	0.727	0.625
	b	0.312	0.310	0.250	0.300	0.400	0.273	0.375
Mod-2	a	0.391	0.362	0.341	0.450	0.029	0.023	0.0
	b	0.609	0.638	0.659	0.550	0.971	0.977	1.000
Pgm	a	0.703	0.828	0.682	0.900	0.957	0.955	1.000
	b	0.297	0.172	0.318	0.100	0.043	0.045	0.0
Mpi	a	0.047	0.034	0.045	0.0	0.129	0.114	0.250
	b	0.953	0.966	0.955	1.000	0.871	0.886	0.750
Acp-1	a	0.563	0.655	0.523	0.600	0.515	0.432	0.417
	b	0.438	0.345	0.477	0.400	0.485	0.568	0.583
Ak-1	a	0.594	0.638	0.864	0.900	0.929	0.818	0.958
	b	0.406	0.362	0.136	0.100	0.071	0.182	0.042
Hk-2	a	0.016	0.034	0.0	0.050	0.0	0.0	0.0
	b	0.0	0.0	0.0	0.0	0.043	0.114	0.083
	c	0.984	0.966	1.000	0.950	0.957	0.886	0.917

Table 2. Summary of F-statistics by locus for the seven roe deer subpopulations. * $p < 0.05$, ** $p < 0.01$, *** $p < 0.001$, NS = not significant.

Locus	F_{IS}	F_{IT}	F_{ST}
Pep-B	-0.022 NS	-0.011 NS	0.011 NS
Mod-2	0.128 NS	0.298***	0.195***
Pgm	0.116 NS	0.218**	0.115***
Mpi	0.362**	0.410***	0.076*
Acp-1	-0.142 NS	-0.113 NS	0.025 NS
Ak-1	0.007 NS	0.122 NS	0.117***
Hk-2	0.063 NS	0.099 NS	0.038*
Mean	0.023 NS	0.100 NS	0.079***

Mpi loci). At Mpi the deviation from equilibrium within subpopulations and relative to the whole population was also indicated by the significant positive values of F_{IS} ($p < 0.01$, Tab. 2) and F_{IT} ($p < 0.001$). The average F_{ST} value of 0.079 was significantly different from zero ($p < 0.001$, Tab. 2), pointing out that approximately 8% of the total amount of genetic variation was due to differentiation among subpopulations. The F_{ST} value yielded an estimate mNe (WRIGHT 1931) of 3.0.

Expected heterozygosities in the subpopulations of Siena (Tab. 3) ranged from 0.046 in VAS to 0.060 in CN, with a mean value of 0.053 (SD 0.007). Arezzo showed

an expected average heterozygosity of 0.040 (SD 0.002) with values for subpopulations ranging from 0.039 in both CAS and VT to 0.043 in CF. The proportion of polymorphic loci ranged from 0.125 to 0.175, with mean values of 0.162 (SD 0.014) and 0.158 (SD 0.029) in Siena and Arezzo, respectively. Genetic distances - Nei's (1972) standard D and modified Rogers D (WRIGHT 1978) are given in table 4. Mean values of genetic distances averaged by province were Nei's D 0.007 (SD 0.002) and modified Rogers D 0.084 (SD

0.011). A rooted tree (UPGMA) and unrooted dendrograms (Fitch-Margoliash tree, Wagner network) displaying genetic relationships among subpopulations are shown in figure 2.

Table 3. Indices of genetic variability in seven roe deer subpopulations from central Italy.

h_o (h_e) = observed (expected) heterozygosity (calculated over 40 loci), P = proportion of polymorphic loci (0.99 criterion), n = mean number of alleles per locus.

	Populations								
	Siena				Mean/SD	Arezzo			Mean/SD
	CN	CS	BAG	VAS		CAS	CF	VT	
h_o	0.061	0.057	0.056	0.040	0.053/0.009	0.038	0.039	0.038	0.038/0.000
h_e	0.060	0.056	0.052	0.046	0.053/0.007	0.039	0.043	0.039	0.040/0.002
P	0.175	0.175	0.150	0.150	0.162/0.014	0.175	0.175	0.125	0.158/0.029
n	1.17	1.17	1.15	1.15		0.17	1.17	1.13	

Table 4. Nei's (1972) standard genetic distance (above diagonal) and modified Rogers distance (WRIGHT 1978, below diagonal) among the seven roe deer subpopulations studied.

	CN	CS	BAG	VAS	CAS	CF	VT
CN	–	0.001	0.002	0.004	0.009	0.007	0.012
CS	0.026	–	0.003	0.002	0.007	0.006	0.010
BAG	0.045	0.049	–	0.002	0.005	0.005	0.008
VAS	0.059	0.046	0.043	–	0.006	0.006	0.008
CAS	0.090	0.079	0.072	0.074	–	0.001	0.001
CF	0.084	0.076	0.071	0.078	0.032	–	0.001
VT	0.186	0.097	0.087	0.090	0.027	0.036	–

(A)

c.c. = 0.894

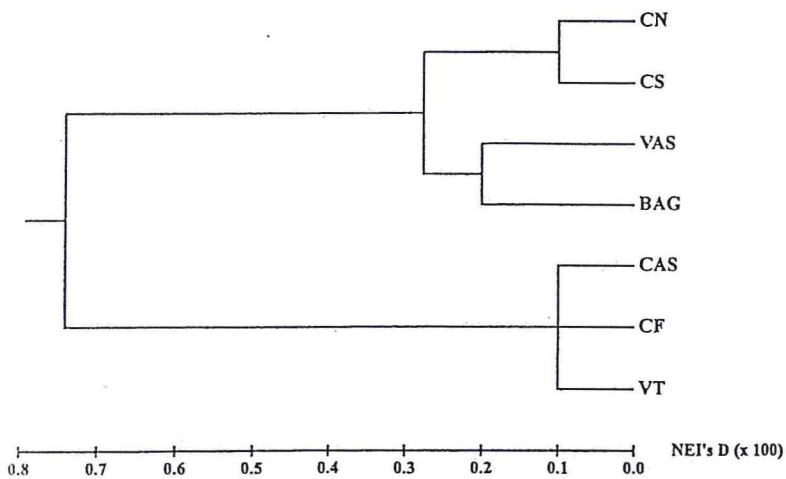

Fig. 2 (A)

(B)

c.c. = 0.992

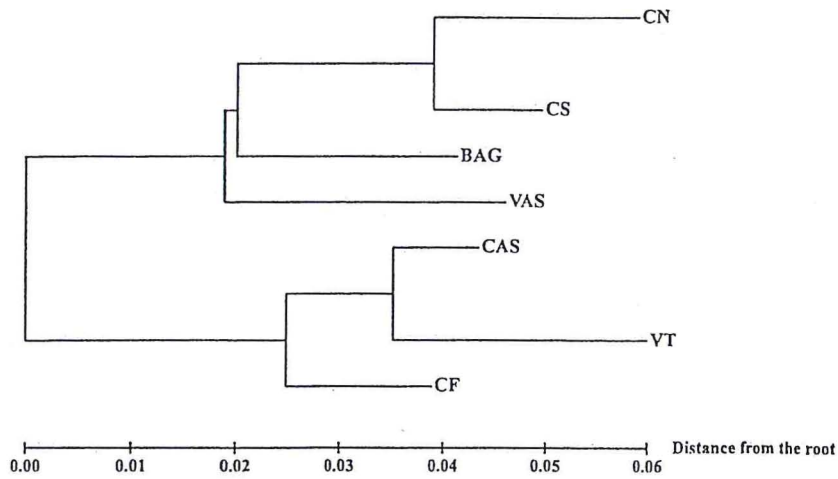

Fig. 2 (B)

(C)

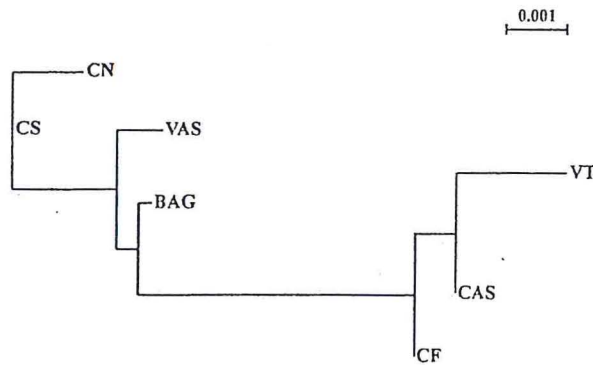

Fig. 2 (C)

Fig. 2. Genetic relationships among the seven roe deer subpopulations studied. (A) NEI's (1972) D/ rooted UPGMA. (B) Modified Rogers D (WRIGHT 1978)/distance Wagner tree with midpoint rooting (FARRIS 1972). (C) NEI's (1972) D/unrooted Fitch-Margoliash tree (negative branch lengths not allowed). c.c. = cophenetic correlation.

Morphologic measurements

Univariate t-test revealed significant differences in 15 out of 28 morphometric characters between skull samples (Tab. 5). Appreciable differences involved all the cranial dimensions, the measurements being generally larger in the skulls from the Arezzo than those from the Siena population. All the length dimensions (CBL, BASL, LFL, PML, PRL, TSL, COLM, PRML), except length of the upper third molar (M3LE), showed greater mean values in Arezzo, whereas most of the dimensions defining the width of the skull

Table 5. Mean (\bar{x}), standard deviation (SD), coefficient of variation (CV), and univariate t-test of 28 variables measured on skulls of roe deer from central Italy.

Character ^a	Siena n = 24			Arezzo n = 24			t
	\bar{x}	(SD)	CV	\bar{x}	(SD)	CV	
CBL ^b	186	(4.69)	2.5	192	(6.56)	3.4	***
BASL	173	(4.71)	2.7	179	(6.18)	3.4	***
LFL	98	(3.40)	3.4	104	(3.99)	3.8	***
PML	57	(2.15)	3.7	58	(2.92)	5.0	*
PRL	46	(2.59)	5.5	49	(2.69)	5.6	**
NASL	59	(2.85)	4.8	61	(3.83)	6.3	ns
TSL	195	(4.27)	2.2	202	(6.88)	3.4	**
NASW	24	(1.64)	6.7	26	(2.40)	9.1	*
FRW	89	(2.26)	3.2	89	(4.42)	4.9	ns
ORW	62	(2.13)	3.4	63	(2.87)	4.5	ns
NEUW	62	(2.30)	3.7	59	(2.79)	4.7	***
COW	35	(1.73)	4.9	37	(1.37)	3.6	***
ZYW	93	(2.45)	2.6	93	(3.28)	3.5	ns
RPW	20	(1.56)	7.6	19	(1.74)	9.1	**
LPW	20	(1.64)	7.9	19	(1.91)	9.9	*
M3L	115	(3.05)	2.6	116	(4.18)	3.6	ns
CMW	16	(1.17)	6.9	16	(1.56)	9.3	ns
PMAL	27	(1.37)	4.9	27	(1.36)	4.9	ns
MTL	31	(1.62)	5.2	31	(1.31)	4.1	ns
M3LE	10	(0.57)	5.6	9	(0.63)	6.6	**
COLM	155	(3.90)	2.5	159	(5.90)	3.7	**
HEM	90	(2.94)	3.2	86	(4.65)	5.3	**
DL	42	(2.23)	5.3	42	(3.37)	7.9	ns
TRL	66	(2.91)	4.4	67	(2.87)	4.3	ns
GOLM	156	(3.47)	2.2	159	(5.66)	3.6	ns
PRML	26	(1.05)	3.9	27	(1.10)	4.0	**
MML	38	(1.72)	4.5	39	(1.84)	4.7	ns
M3MA	14	(0.85)	5.8	15	(0.96)	6.4	ns

* = $p < 0.05$, ** = $p < 0.01$, *** = $p < 0.001$, ns = not significant

^a All measurements are in mm

^b See text for explanation of variable acronyms

were not significantly different between samples (FRW, ORW, ZYW, CMW) or attained higher mean values in Siena (LPW, RPW, NEUW; Fig. 3). The only measure related to the height of the skull (HEM) was significantly greater in Siena as well. Lower variability of morphometric characters was recorded in the latter population, as suggested by its generally smaller coefficients of variation. Values of CV range from 2.2 to 7.9 in Siena and from 3.4 to 9.9 in Arezzo, breadth across the nasala (NASW), width of pedicles (RPW, LPW) and width at the crest of the maxilla (CMW) showing higher variation than other skull measurements (Wilcoxon signed-ranks test = 3.7, $p < 0.001$).

Principal component analysis of log₁₀-transformed data extracted six components with eigenvalues greater than 1. The first component (PC-I) explained 40% of the total amount of phenotypic variability (Fig. 4). The other five components altogether accounted for an additional 45% of variation. The first component was of the size-type, with all coefficients positive, which suggests an influence of overall skull size on group separation (in Fig. 4 only coefficients equal to or greater than 0.5 are shown). The second (PC-II) and the third (PC-III) factor explained 14% of the variance each, mandibular

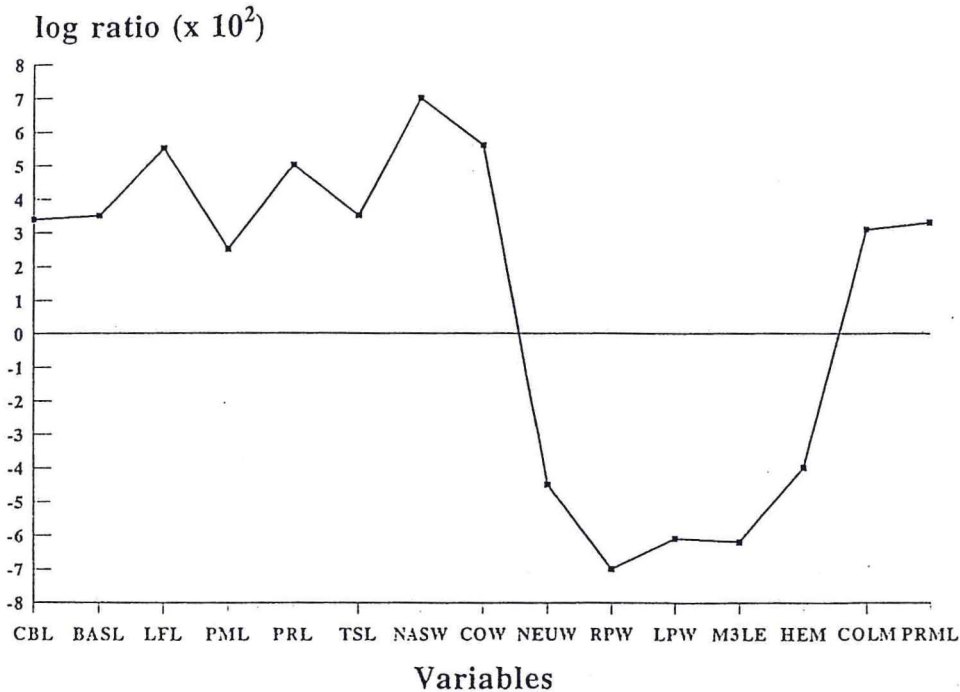

Fig. 3. Diagram showing variables significantly greater in the population from Arezzo (squares in the upper part of the graph) and in that from Siena (squares in the lower part of the graph), expressed as logarithms of the ratios of mean values.

(TRL, PRML, MML, M3MA) and maxillar (PMAL, MTL) length dimensions showing highly positive loadings on PC-II, whereas zygomatic width (ZYW), width of the right (RPW) and the left pedicle (LPW) loading positively on PC-III. Minimum width at the crest of the maxilla (CMW) had a positive loading on PC-IV (not shown). Three characters loaded positively on the fifth component PC-V (M3LE, NEUW, HEM). It explained only 4% of the variation. However, since most of the measurements which were significantly greater in Siena (Tab. 5) loaded on this axis, it was the only one that, projected on PC-I, allowed that samples overlapped only slightly, thus forming two quite distinct clusters of points (Fig. 4). The structure of variable loadings suggests that roe deer with relatively shorter and broader skulls tended to have negative values on PC-I and positive values on PC-V.

Out of the six components extracted by PCA, only the ones that minimized the Wilks' lambda (PC-I to PC-VI, PC-IV excluded) were entered in the discriminant analysis. Because of the maximization of distances, DFA was more efficient in separating the groups, which appeared as clearly separated clusters (Fig. 5). A new classification of the data based on the results of this analysis prevented misidentifications, since 100% of cases were correctly classified.

When the relative values of measurements were used to calculate PCA, the remaining phenotypic variation between groups was reduced (Fig. 6). The percentage of variance accounted for by the first principal components was smaller than that obtained using the absolute data. Eight components had to be extracted to exceed 80% of total variation explained. Clusters formed by PC-II projected on PC-I showed a wider overlap as a conse-

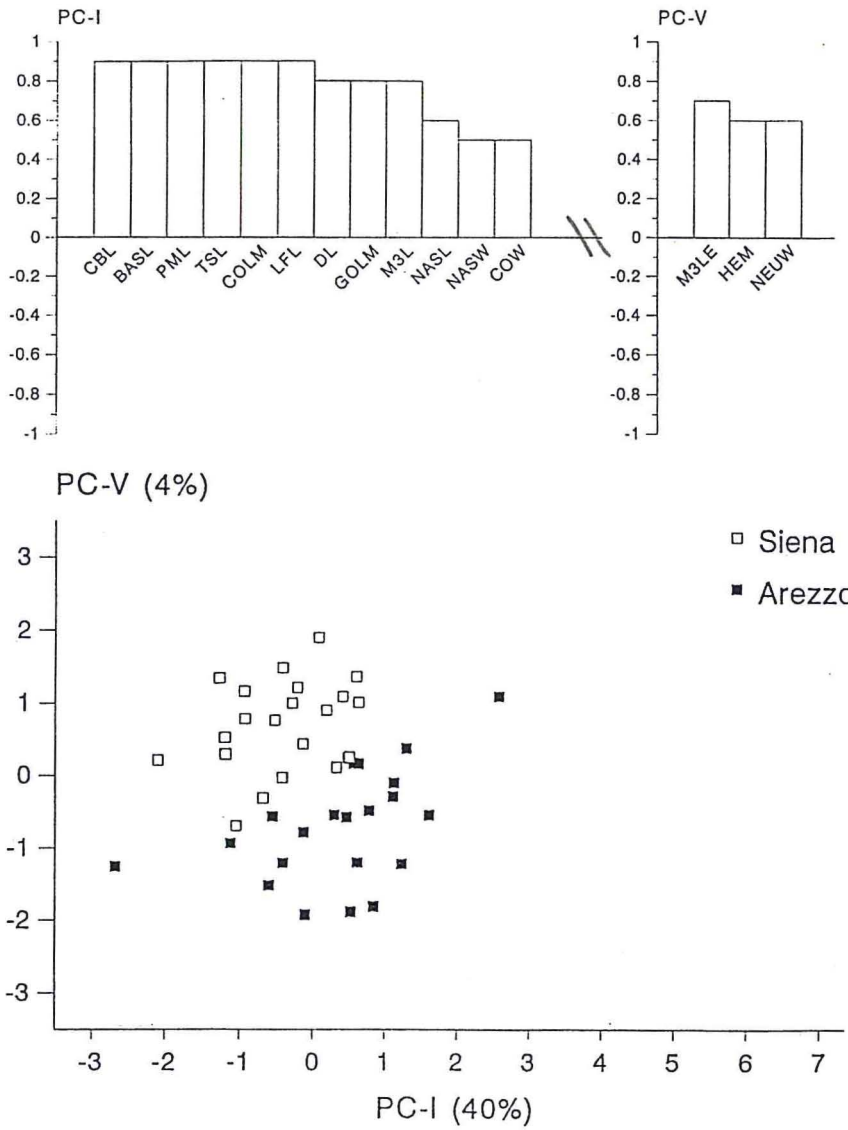

Fig. 4. Principal component analysis of the log.-transformed values of 28 cranial measurements in two roe deer populations of central Italy. The loadings of variables relative to axes I and V are shown in the upper part of the graph (only loadings equal to or greater than 0.5 are shown). The percentage variation explained by each axis is given in parentheses.

quence of the size effect of the skull which had been partly removed. Similar pictures were obtained by projecting further principal components (not shown). The first and the second components accounted for 27% and 16% of variation, respectively (Fig. 6). Most of the tooth length dimensions related to the mandible (MML, TRL, PRML, M3MA) and the maxilla (MTL, M3L, PMAL, M3LE) had all high positive loadings on PC-I, which can be interpreted again as a general size axis. As happened with the absolute data, variables failed to provide a good separation of groups along this axis. The values of vari-

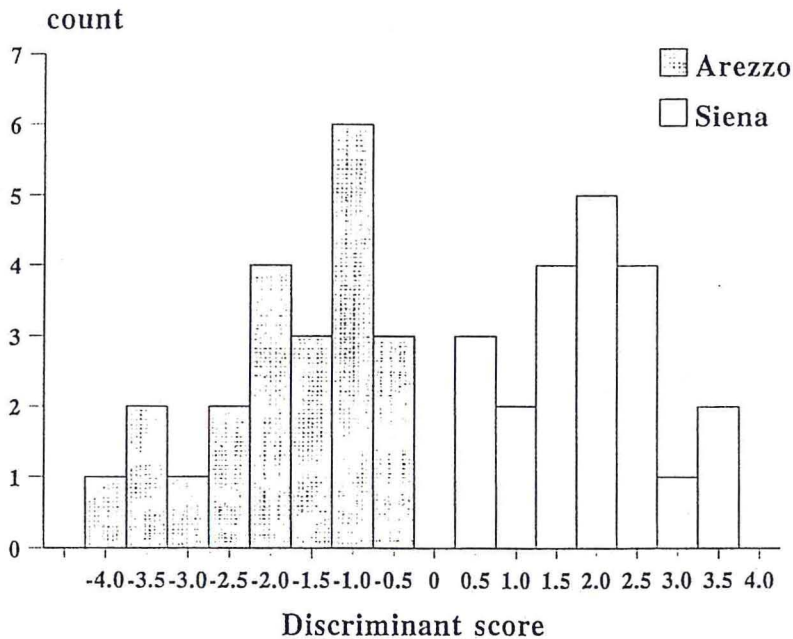

Fig. 5. Histogram of discriminant scores of the log-transformed values.

able loadings on PC-II differed in magnitude and sign, implying a contrast between width (RPW, LPW, ZYW, FRW, NEUW) and length (LFL) of the skull. Roe deer with long and narrow skulls tended to have relatively large negative values on this axis. Other factors were not important since the percent of variation they accounted for was very low. Thus, the separation of the two samples was mostly attributable to differences in both the size and shape of the skulls.

DFA was once again more efficient than PCA in identifying Siena and Arezzo specimens as different groups. The plot of discriminant function scores shows slightly overlapping clusters (Fig. 7). Only two out of 48 skulls analysed were misidentified (95% of cases were correctly classified).

Discussion

Recent investigations revealed that, in contrast to other cervids such as the fallow deer, *Dama dama* (PEMBERTON and SMITH 1985; HARTL et al. 1986; RANDI and APOLLONIO 1988), the moose, *Alces alces* (RYMAN et al. 1980; BACCUS et al. 1983), the red deer, *Cervus elaphus* (GYLLENSTEN et al. 1983; HARTL et al. 1990) and the sika deer, *Cervus nippon* (HERZOG 1988; MARKOV et al. 1992), roe deer exhibit high levels of protein variation (HARTL et al. 1991; WEHNER et al. 1991; LORENZINI et al. 1993; HEWISON 1995). Values of expected average heterozygosity and polymorphism obtained in this study suggest that the roe deer is among the deer species with highest levels of genetic variability within populations (cf. SHEFFIELD et al. 1985; RØED 1985; HARTL et al. 1993; MÖRSCH and LEIBENGUTH 1994). In previous studies, based on comparable sets of biochemical markers screened, polymorphisms were observed nearly at the same loci in different European populations (HARTL et al. 1991, 1993; LORENZINI et al. 1993). Not surprisingly, the same vari-

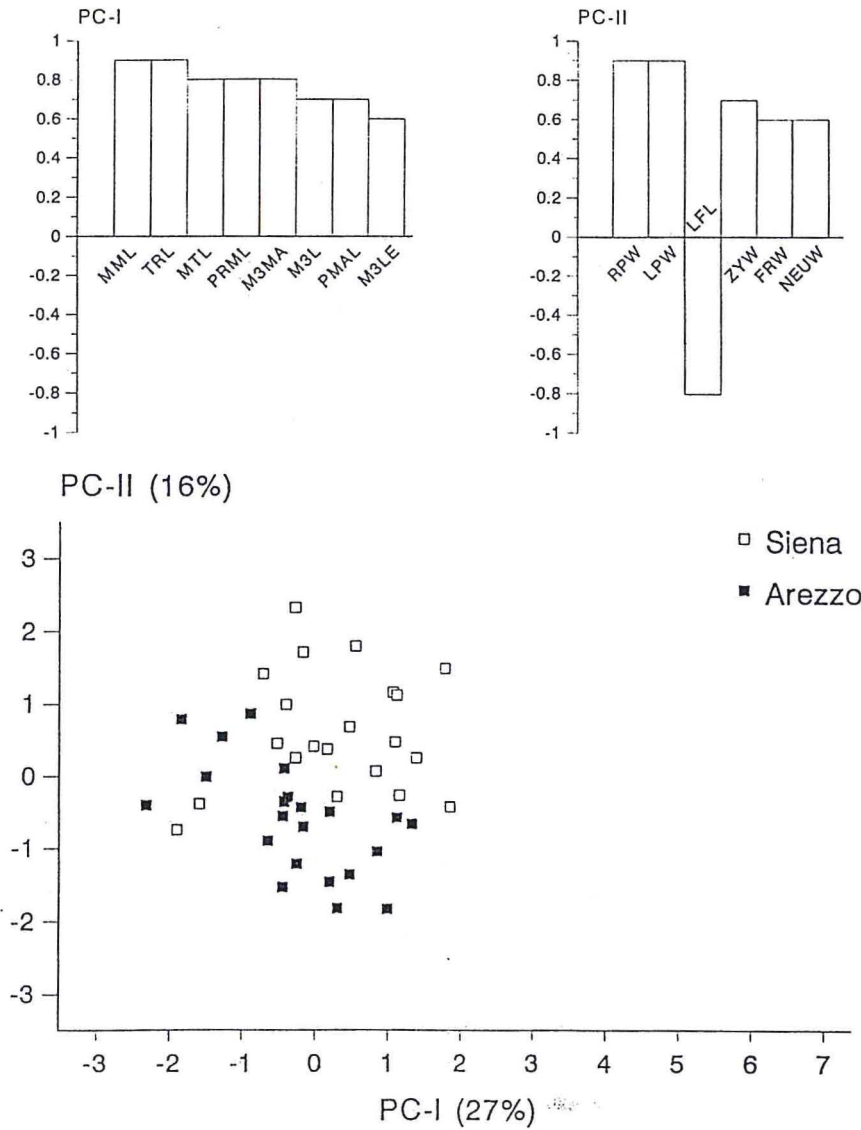

Fig. 6. Principal component analysis of the relative (divided by total skull length) values of 28 cranial measurements.

able loci were found in all the Italian roe deer subpopulations under study, except those in which the small sample size might have influenced the finding of the less frequent alleles. Patterns of allele frequency distribution at polymorphic loci showed considerable genetic homogeneity among the subpopulations of the same province, revealing the absence of a relevant microgeographic differentiation. Subpopulations formed two major clusters in both the rooted and unrooted trees, as expected from patterns of allelic diversity. Within both the “Siena” and the “Arezzo” groups, the clustering of subpopulations remained basically unchanged, regardless of their low genetic distance and unequal sample sizes. In each province, samples from different sites revealed no significant genetic di-

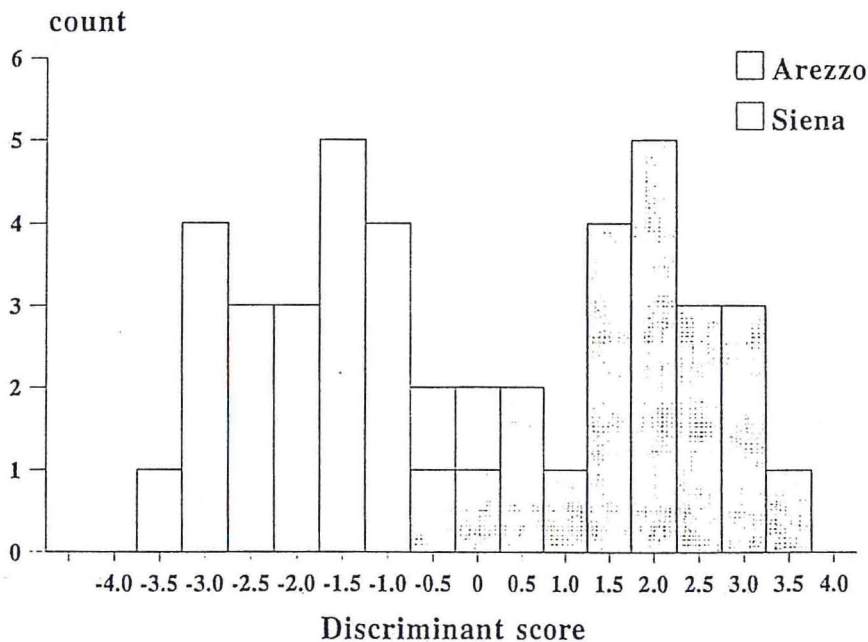

Fig. 7. Histogram of discriminant scores of the relative values.

versity, leaving the main differentiation to the whole populations of Siena and Arezzo. In the subpopulations of Siena H- and P- values were among the highest as yet detected in this species (BACCUS et al. 1983; HARTL et al. 1991, 1993, WEHNER et al. 1991).

The relative genetic differentiation of 8% was well in the range of values obtained in other investigations (6.4%, 8.5%, and 12.6% HARTL et al. 1993, 1988, 1991). NEI's (1972) absolute genetic distance between the two main populations was similar to or slightly higher than the values obtained previously in this species and generally for local populations in deer (RYMAN et al. 1980; PEMBERTON and SMITH 1985; RØED 1986; HARTL et al. 1990).

The effects of random drift could account for the differences in allele frequencies and distribution of polymorphisms in the roe deer from Siena and Arezzo. By contrast, they are not pronounced enough to be explained by different selective pressures. The human influence and the eco-geographical conditions of their habitats are, on average, very similar indeed, as revealed also by the lack of microgeographic structuring. Therefore, during the relative short time the populations have inhabited those regions, environmental constraints and selection should have acted in a similar way, thus preventing any noticeable genotype differentiation. Moreover, they have lived as neighbouring populations for the last few years, so that some extent of gene flow exists, which might have prevented a substantial genetic isolation (SLATKIN 1987; MAYNARD SMITH 1991). There must be a demographic explanation (LORENZINI et al. 1993). The contribution of different gene pools to the population of Siena possibly produced a high heterozygosity. However, we cannot exclude that a higher level of genetic variability was proper to the original stock, native of the Latium Maremma. The Arezzo population did not experience any remarkable introduction of allochthonous genotypes from outside, or suffered any drastic demographic event which could reduce its variability. Thus, the heterozygosity of the original nucleus was retained.

As far as the morphometrical analysis of skulls and mandibles is concerned, size variation was the main source of difference between samples, skulls of the Arezzo population being generally larger than those of the Siena population. Nevertheless, some differences in shape were also apparent, mostly when the ratios of measurements were used. Due to a different approach in gathering the morphometric measurements, the set of characters used in this investigation is not fully comparable with that of previous studies. In spite of this, some rough comparisons could be made with the data from other European populations. Such comparisons revealed that the Arezzo roe deer have greater skull dimensions than those studied so far, whereas roe deer from Siena are more similar to the ones described in the literature (MEUNIER 1981; ZEJDA and KOUBEK 1988; ZIMA et al. 1989; FANDOS and REIG 1993, FANDOS 1994). Moreover, the level of cranial differentiation obtained in this study is higher than the ones reported in other investigations, where no evidence of shape differences was found among local populations (ZEJDA and KOUBEK 1988; FANDOS and REIG 1993).

Some divergence between samples was first suggested by the univariate comparisons of means, and became more evident from the discriminant analysis. This method, better than principal component analysis, allowed full separation of the two sets of skulls, when log. transformations of absolute data were used. Even when discriminant analysis was performed with the relative values, the residual phenotypic variation allowed a quite clear separation of the two populations. Only one skull per sample was identified as belonging to the other a-priori subdivided group on the basis of the discriminant scores.

The pattern of allele frequencies revealed that a genetic factor is involved in the diversification of the Siena and Arezzo populations due to their different historical backgrounds. However, when dealing with metrical traits, the environmental component is also of great importance. Beyond the complexity of the gene-environment interactions, it remains problematic to understand and to quantify which environmental factor affects the observed phenotypic variation. In our case, overall food resources and environmental stability of the habitats are very similar for both the roe deer populations. On the other hand, the population densities within the wooded areas are considerably different in the two provinces. Density is one of the main factors in the dynamics and the ecology of populations (RICKLEFS 1979). Density proved to be a significant factor for the social organization of deer populations, affecting behaviour and reproduction (APOLLONIO et al. 1991; VINCENT and BIDEAU 1992). The emergence of the new ecological form of field roe deer has been interpreted as the result of the overcrowding of forest populations due to persistent habitat degradation, which was followed by movements of the animals towards agricultural landscapes (PIELOWSKI 1977; PIELOWSKI and BRESIŃSKI 1982).

High densities increase the interactions among individuals for food supplies, and between males during the rutting period (KLEIN and STRANDGAARD 1972; KURT 1991). In the province of Siena the high density in forested areas could cause a stronger individual competition and, on average, poorer feeding conditions. The latter may affect growth, weight, body size and other morpho-physiological traits. In the Arezzo population this situation may have occurred less intensively, due to the lower density in the wooded areas. There, roe deer have larger body sizes and longer skulls. LOVARI et al. (1991) reported that also lower jaw and metatarsal dimensions are greater in roe deer from Arezzo than in those from Siena. Moreover, MEUNIER (1981) showed that the growth of some cranial dimensions can be influenced by changing conveniently the dietary regimes, lengths increasing more than widths.

Significant differences in cranial, mandibular and antler dimensions have been documented between populations from two geographically separated regions in former Czechoslovakia (ZEJDA and KOUBEK 1988). However, a precise cause-effect relationship between variation of morphological traits and environmental effects could not be found. In contrast to our results, the Czechoslovakian roe deer which lives at high density had

larger body sizes and greater cranial dimensions than those living at lower densities. However, the latter are supported by poorer quality food, so that density is not the principal limiting factor.

Acknowledgements

We wish to thank R. MAZZONI DELLA STELLA for his contribution in providing the samples of Siena and in tracing the history of the same population. We are also grateful to the local hunters and to the D.R.E.A.M. team (C. LOVARI, V. MAZZARONE, P. PEDONE, and N. SIEMONI) for their assistance in the field. Special thanks are addressed to G. HARTL, S. LOVARI, J. MARKOWSKI, F. SUCHENTRUNK, and S. MATTIOLI for their comments on an earlier version of the manuscript. The graphical help of S. SANTARELLI is gratefully acknowledged. The German summary was graciously provided by CLAUDIA WEISS.

Zusammenfassung

Allozym- und kraniometrische Variabilität bei Rehen (Capreolus capreolus) aus Mittelitalien

Rehe aus den Provinzen Siena und Arezzo, Mittelitalien, wurden auf genetische und morphologische Differenzierung untersucht. Bei insgesamt 162 Individuen aus sieben Stichprobengebieten (4 in Siena, 3 in Arezzo) wurde mittels vertikaler Polyacrylamidgel-Elektrophorese die Variabilität an 40 hypothetischen Strukturgenloci erfaßt. Sieben Loci waren für mindestens zwei Allele polymorph. Die durchschnittliche Polymorphierate (P) betrug in Siena 16,2% (s = 1,4%) und in Arezzo 15,8% (s = 2,9%). Der durchschnittliche erwartete Heterozygotiegrad (H_e) betrug in Siena 5,3% (s = 0,7%) und in Arezzo 4,0% (s = 0,2%). Sowohl die relative ($F_{ST} = 8\%$) als auch die absolute (\bar{D} nach Nei 1972 = 0,007, s = 0,002; \bar{D} nach Rogers = 0,084, s = 0,011) genetische Distanz zeigen eine deutliche Separierung der Stichproben aus Siena von jenen aus Arezzo, was auf die unterschiedliche Herkunft der Rehbestände zurückzuführen sein dürfte. Die bei insgesamt 48 Individuen gemessene morphometrische Variabilität in 28 Schädelmaßen wurde einer Hauptkomponentenanalyse und einer Diskriminanzanalyse unterworfen. Beide Methoden zeigten eine klare morphometrische Differenzierung zwischen den Individuen aus den jeweiligen Provinzen. Die Rehe aus Arezzo wiesen signifikant größere Schädelmaße auf. Obwohl auch genetische Faktoren eine Rolle spielen könnten, betrachten wir die höhere Individuendichte der Rehe in den Waldgebieten von Siena als Hauptursache für diesen Befund.

References

- AITKEN, R. J. (1975): Cementum layers and tooth wear as criteria for ageing roe deer (*Capreolus capreolus*). *J. Zool.* (London) 175, 15–28.
- ANDERSON, T. W. (1971): An introduction to multivariate analysis. New York: J. Wiley and Son.
- APOLLONIO, M.; STRIGLIONI, F.; SCHENONE, L.; SPANO, S. (1991): Different mating systems in fallow deer, possible consequences of high density on reproduction costs. *Ongulés/Ungulates* 91. Toulouse, Abstracts, 5.
- APOLLONIO, M.; HARTL, G. B. (1993): Are biochemical-genetic variation and mating systems related in large mammals? In: *Ecological Genetics in Mammals*. Ed. by G. B. HARTL and J. MARKOWSKI. *Acta theriol.* 38, Suppl. 2, 175–185.
- BACCUS, R.; RYMAN, N.; SMITH, M. H.; REUTERWALL, C.; CAMERON, D. (1983): Genetic variability and differentiation of large grazing mammals. *J. Mammalogy* 64, 109–120.
- CRUDELE, G. (1988): La fauna. In: *Le foreste di Campigna-Lama nell'Appennino Tosco Romagnolo*. Ed. by M. PADULA and G. CRUDELE. Regione Emilia Romagna, Bologna, 325–401.
- DRIESCH, A. VON DEN (1976): A guide to the measurement of animal bones from archeological sites. *Peabody Mus. Bull.*, Univ. Harvard Press, 35–57.
- FANDOS, P. (1994): Skull biometry of Spanish roe deer (*Capreolus capreolus*). *Folia Zool.* 43, 11–20.
- FANDOS, P.; ORUETA, J. F. (1991): Morphological variations of the roe deer skull (*Capreolus capreolus* L.). *Doñana, Acta Vertebrata* 18, 159–171.

- FANDOS, P.; REIG, S. (1993): Craniometric variability in two populations of roe deer (*Capreolus capreolus*) from Spain. *J. Zool. (London)* 231, 39–49.
- FARRIS, J. S. (1972): Estimating phylogenetic trees from distance matrices. *Amer. Nat.* 106, 645–668.
- FELSENSTEIN, J. (1979): Alternative methods of phylogenetic inference and their interrelationship. *Syst. Zool.* 29, 49–62.
- FRUZIŃSKI, B.; ŁABUDZKI, L. (1982): Demographic processes in the forest roe deer population. *Acta theriol.* 27, 377–384.
- FRUZIŃSKI, B.; KALUZIŃSKI, J.; BAKSALARY, J. (1982): Weight and body measurements of forest and field roe deer. *Acta theriol.* 27, 479–488.
- GOTTSCHLICH, H. J. (1982): Vergleichende Untersuchungen über das Schädelwachstum bei Rot- und Rehwild. *Beitr. Jagd- und Wildforschung* 3, 81–92.
- GOULSON, D. (1994): Allozyme variation in the butterfly, *Maniola jurtina* (Lepidoptera: Satyrinae L.): evidence for selection. *Heredity* 71, 386–393.
- GYLLENSTEIN, U.; RYMAN, N.; REUTERWALL, C.; DRATCH, P. (1983): Genetic differentiation in four European subspecies of red deer (*Cervus elaphus* L.). *Heredity* 51, 561–580.
- HANUS, V.; FISER, Z. (1979): Craniological measurements in the roebuck (*Capreolus c. capreolus* L.). *Folia Venat.* 9, 15–32.
- HARRIS, H.; HOPKINSON, D. A. (1976): Handbook of enzyme electrophoresis in human genetics. Amsterdam: North Holland.
- HARTL, G. B.; REIMOSER, F. (1988): Biochemical variation in roe deer (*Capreolus capreolus* L.): are r-strategists among deer generally less variable than k-strategists? *Heredity* 60, 221–227.
- HARTL, G. B.; SCHLEGER, M.; SLOWAK, M. (1986): Genetic variability in fallow deer, *Dama dama* L. *Anim. Genet.* 17, 335–341.
- HARTL, G. B.; REIMOSER, F.; WILLING, R.; KÖLLER, J. (1991): Genetic variability and differentiation in roe deer (*Capreolus capreolus* L.) of Central Europe. *Genet. Sel. Evol.* 23, 281–299.
- HARTL, G. B.; WILLING, R.; LANG, G.; KLEIN, F.; KÖLLER, J. (1990): Genetic variability and differentiation in red deer (*Cervus elaphus* L.) of Central Europe. *Genet. Sel. Evol.* 22, 289–306.
- HARTL, G. B.; MARKOV, G.; RUBIN, A.; FINDO, S.; LANG, G.; WILLING, R. (1993): Allozyme diversity within and among populations of three ungulate species (*Cervus elaphus*, *Capreolus capreolus*, *Sus scrofa*) of Southeastern and Central Europe. *Z. Säugetierkunde* 58, 352–361.
- HERZOG, S. (1988): Polymorphism and genetic control of erythrocyte 6-phosphogluconate dehydrogenase in the genus *Cervus*. *Anim. Genet.* 19, 291–294.
- HEWISON, A. J. M. (1995): Isozyme variation in roe deer in relation to their population history in Britain. *J. Zool. (London)* 235, 279–288.
- KLEIN, D. R.; STRANDGAARD, H. (1972): Factors affecting growth and body size of roe deer. *J. Wild. Manage.* 36, 64–79.
- KURT, F. (1991): Das Reh in der Kulturlandschaft – Sozialverhalten und Ökologie eines Anpassers. Hamburg, Berlin: Paul Parey.
- KURT, F.; HARTL, G. B.; VÖLK, F. (1993): Breeding strategies and genetic variation in European roe deer *Capreolus capreolus* populations. In: *Ecological Genetics in Mammals*. Ed. by G. B. HARTL and J. MARKOWSKI. *Acta theriol.* 38, Suppl. 2, 187–194.
- LEHMANN, E. VON; SÄGESSER, H. (1986): *Capreolus capreolus* Linnaeus, 1758. In: *Handbuch der Säugetiere Europas*. Vol. 2/II. Ed. by J. NIETHAMMER and F. KRAPP. Wiesbaden, Aula-Verlag. Pp. 233–268.
- LORENZINI, R.; PATALANO, M.; APOLLONIO, M.; MAZZARONE, V. (1993): Genetic variability of roe deer *Capreolus capreolus* in Italy: electrophoretic survey on populations of different origin. In: *Ecological Genetics in Mammals*. Ed. by G. B. HARTL and J. MARKOWSKI. *Acta theriol.* 38, Suppl. 2, 141–151.
- LOVARI, C.; MATTIOLI, L.; MAZZARONE, V.; SIEMONI, N.; PEDONE, P. (1991): Biometric statistics of two populations of roe deer (*Capreolus capreolus* L.) in Tuscany, Italy. In: *Ongulés/Ungulates* 91. Ed. by F. SPITZ, G. JANEAU, G. GONZALEZ, and S. AULAGNIER. Toulouse: S.F.E.P.M. – I.R.G.M., 133–136.
- MAJEWSKA, B.; PIELOWSKI, Z.; LABUDZKI, L. (1982): The level of some energy metabolism indices in forest and field populations of roe deer. *Acta theriol.* 27, 471–477.
- MARKOV, G.; DANILKIN, A.; HARTL, G. B. (1992): Lack of biochemical-genetic variation in native sika deer (*Cervus nippon hortularum*) from the far east of the Asian continent. *Z. Säugetierkunde* 57, 118–119.
- MARKOWSKI, J. (1993): Fluctuating asymmetry as an indicator for differentiation among roe deer *Capreolus capreolus* populations. In: *Ecological Genetics in Mammals*. Ed. by G. B. HARTL and J. MARKOWSKI. *Acta theriol.* 38, Suppl. 2, 19–31.

- MARKOWSKI, J.; MARKOWSKA, M. (1988): Non-metrical variation in three populations of roe deer. *Acta theriol.* 33, 519–536.
- MAYNARD SMITH, J. (1989): *Evolutionary Genetics*. Oxford: Univ. Oxford Press.
- MATTIOLI, S. (1994): Le reintroduzioni di cervidi in Italia, con particolare riferimento all'Appennino. In: *I Convegno Barrasso: La fauna appenninica e la sua conservazione*. Ed. by M. INGLISA. Pp. 19–25.
- MAZZONI DELLA STELLA, R. (1991): Indagine sulla presenza del capriolo e del daino nella provincia di Siena. *Amministrazione Provinciale di Siena*. Pp. 1–65.
- MEUNIER, K. (1981): Analyse der Größen- und Proportionsverhältnisse. In: *Über Rehe in einem steirischen Gebirgsrevier*. 3. Aufl. Ed. by A. V. BAYERN and J. V. BAYERN. Muenchen: Bayerischer Landwirtschaftsverlag. Pp. 141–146.
- MORRISON, D. F. (1976): *Multivariate statistical methods*. London: McGraw-Hill.
- MÖRSCH, G.; LEIBENGUTH, F. (1994): DNA fingerprinting in roe deer using the digoxigenate probe (GTG) 5. *Anim. Genet.* 25, 25–30.
- MURPHY, R. W.; SITES, J. W.; DONALD, G. B.; HAUFLE, C. H. (1990): Protein I: Isozyme Electrophoresis. In: *Molecular Systematics*. Ed. by D. M. HILLIS and C. MORITZ. Sunderland, Massachusetts, USA: Sinauer Ass.
- NEI, M. (1972): Genetic distance between populations. *Am. Nat.* 106, 283–292.
- NEI, M. (1977): F-statistics and analysis of gene diversity in subdivided populations. *Ann. Human Genet.* 41, 225–233.
- NEUHAUS, A. H.; SCHAICH, K. (1985): *Das Rehwild*. Hamburg, Berlin: Paul Parey.
- NIE, N. H.; HULL, C. H.; JENKINS, J. G.; STEINBRENNER, K.; BENT, D. H. (1975): *Statistical package for the social sciences*. New York: Mc Graw-Hill.
- PEMBERTON, J. M.; SMITH, R. H. (1985): Lack of biochemical polymorphism in British fallow deer. *Heredity* 55, 199–207.
- PIELOWSKI, Z. (1977): Das Feldreh. Wild der Zukunft in der Agrarlandschaft. *Beitr. Jagd- und Wildforsch.* 10, 193–200.
- PIELOWSKI, Z.; BRESIŃSKI, W. (1982): Population characteristics of roe deer inhabiting a small forest. *Acta theriol.* 27, 409–425.
- RANDI, E.; APOLLONIO, M. (1988): Low biochemical variability in European fallow deer (*Dama dama* L.): natural bottlenecks and the effect of domestication. *Heredity* 61, 405–410.
- RICKLEFS, R. E. (1979): *Ecology*. 2nd ed. Middlesex, UK: Nelson.
- RØED, K. H. (1985): Genetic variability in Norwegian semi-domestic reindeer (*Rangifer tarandus* L.). *Hereditas* 102, 177–184.
- RØED, K. H. (1986): Genetic variability in Norwegian wild reindeer (*Rangifer tarandus* L.). *Hereditas* 104, 293–320.
- RYMAN, N.; REUTERWALL, C.; NIGREN, K.; NIGREN, T. (1980): Genetic variation and differentiation in Scandinavian moose (*Alces alces*): are large mammals monomorphic? *Evolution* 34, 1037–1050.
- SHAW, C. R.; PRASAD, R. (1970): Starch gel electrophoresis of enzymes. A compilation of recipes. *Bioch. Genet.* 4, 297–320.
- SHEFFIELD, S. R.; MORGAN, R. P. II; FELDHAMER, G. A.; HARMAN, D. M. (1985): Genetic variation in white-tailed deer (*Odocoileus virginianus*) populations in Western Maryland. *J. Mammalogy* 66, 243–255.
- SLATKIN, M. (1985): Rare alleles as indicators of gene flow. *Evolution* 39, 53–65.
- SLATKIN, M. (1987): Gene flow and the geographic structure of natural populations. *Science* 236, 787–792.
- SNEATH, P. H.; SOKAL, R. R. (1973): *Numerical taxonomy*. San Francisco: W. H. Freeman and Co.
- SOKAL, R. R.; ROHLF, F. J. (1981): *Biometry*. San Francisco: W. H. Freeman and Co.
- SWOFFORD, D. L.; SELANDER, R. K. (1989): Biosys-1. A computer program for the analysis of allelic variation in population genetics and biochemical systematics. Release 1.7. Illinois Nat. Hist. Surv., Champaign.
- VINCENT, J. P.; BIDEAU, P. (1992): Influence of density on spatial and social organization of forest roe deer (*Capreolus capreolus* L.). In: *Ongulés/Ungulates 91*. Ed. by F. SPITZ, G. JANEAU, G. GONZALEZ, and S. AULAGNIER. Toulouse: S.F.E.P.M. – I.R.G.M., 267–269.
- WEHNER, J.; MÜLLER, H. P.; KIERDORF, H. (1991): Untersuchungen zur genetischen Situation ausgewählter rheinischer Rehwild-Populationen unter besonderer Berücksichtigung isolationsbedingter Veränderungen. *Z. Jagdwiss.* 37, 40–48.
- WILLIAMS, B. K.; TITUS, K.; HINES, J. E. (1990): Stability and bias of classification rates in biological applications of discriminant analysis. *J. Wild. Manag.* 54, 331–341.

- WORKMAN, P. L.; NISWANDER, J. D. (1970): Population studies on southwestern Indian tribes. II. Local genetic differentiation in the Papago. *Amer. J. Human Genet.* **22**, 24-49.
- WRIGHT, S. (1931): Evolution in Mendelian populations. *Genetics* **16**, 97-159.
- WRIGHT, S. (1951): The genetical structure of populations. *Ann. Eugenet.* **15**, 323-354.
- WRIGHT, S. (1978): Evolution and the genetics of populations. Vol. 4. Variability within and among natural populations. Chicago: Univ. Chicago Press.
- ZEJDA, J.; KOUBEK, P. (1988): On the geographical variability of roebucks (*Capreolus capreolus*). *Folia Zool.* **37**, 219-229.
- ZIMA, J.; LIBOSVÁRSKY, J.; BAUEROVÁ, Z.; KOUBEK, P.; ZEJDA, J. (1989): Comparison of metric and non-metric morphological distances between four populations of roe-deer (*Capreolus capreolus*). *Folia Zool.* **38**, 45-58.
- ZIMA, J. (1989): Non-metric variability in the skull of roe deer (*Capreolus capreolus*). *Folia Zool.* **38**, 119-137.

Authors' addresses: RITA LORENZINI, MARIANNA PATALANO, Istituto Zooprofilattico Sperimentale dell'Abruzzo e del Molise "G. Caporale", Campo Boario, I-64100 Teramo, Italy; LUCA MATTIOLI, D.R.E.A.M. Settore Fauna, Via Roma 172, I-52014 Poppi, Arezzo, Italy; MARCO RUSTIONI, Dipartimento di Scienze della Terra, Università di Firenze, Via La Pira 4, I-50121 Firenze, Italy.